

OEM pressure sensor For industrial applications Model O-10 (T)

WIKA data sheet PE 81.65



for further approvals see
page 6

Applications

- Hydraulics and pneumatics
- Pumps and compressors
- Machine building

Special features

- Always the ideal solution, whether standard or customer-specific
- Long-term stability – Reliable measured values over the complete lifecycle
- Consistent quality and delivery performance



Pressure sensor model O-10 (T)

Description

The O-10 is a low-cost pressure sensor for universal use in OEM applications at pressure ranges from 6 to 600 bar. The O-10 is compact and can be integrated into many machine designs. In terms of precision and robustness, it offers application-optimised performance. Thanks to a wide range of connections, signals and measuring ranges, the pressure sensor can be integrated effortlessly. Customer-specific and private label solutions can also be realised.

Whether a standard instrument or a customer-specific adaption - always the ideal solution

The O-10 is available in almost 500,000 variants - with approvals for the EU, Russia and also the USA and Canada - and, without the need for special designs, offers the greatest freedom. Whether as a second-source sensor or as a replacement, the O-10 saves time and costs during implementation. For optimised machine designs, customisation is really easy.

Measured values, stable in the long term

With a dry measuring cell, the O-10 operates practically wear-free and delivers enduringly stable and precise measured values. This fully welded thin-film cell has already been proven a million times over in the OEM market. Thanks to high overload resistance and a service life of >100 million load cycles, there are no maintenance and replacement costs. The risk of faults is minimal.

The perfect sensor for large-volume projects

With WIKA, OEM customers benefit from an experienced partner that has been operating as a volume supplier for decades. Delivery reliability and quality assurance are provided consistently through four modern production lines with ISO 9001-based end-of-line checks - for private label solutions too. Units of 50 sensors each make handling easier and reduce packaging waste.

Specifications

Accuracy specifications	
Non-linearity per BFSL per IEC 61298-2	$\leq \pm 0.5\%$ of span ¹⁾
Accuracy	→ See "Max. measured error per IEC 61298-2"
Max. measured error per IEC 61298-2	$\leq \pm 1.2\%$ of span ²⁾
Zero point error	$\leq \pm 0.5\%$ of span
Temperature error at 0 ... 80 °C [32 ... 176 °F]	$\leq \pm 1.5\%$ of span
Long-term stability per DIN 16086	$\leq \pm 0.3\%$ of span/year
Reference conditions	Per IEC 61298-1

- 1) A different non-linearity applies to some measuring ranges, see "Measuring ranges".
 2) A different measuring deviation applies to some measuring ranges, see "Measuring ranges".

Measuring ranges, gauge pressure

bar	
0 ... 6 ^{1) 2)}	0 ... 100
0 ... 10 ^{1) 2)}	0 ... 160
0 ... 16	0 ... 250
0 ... 25	0 ... 400
0 ... 40	0 ... 600
0 ... 60	

- 1) Measuring deviation $\leq \pm 0.7\%$ of span
 2) Non-linearity $\leq \pm 0.6\%$ of span BFSL

psi	
0 ... 100 ^{1) 2)}	0 ... 1,000
0 ... 160	0 ... 1,500
0 ... 200	0 ... 2,000
0 ... 250	0 ... 3,000
0 ... 300	0 ... 4,000
0 ... 400	0 ... 5,000
0 ... 500	0 ... 6,000
0 ... 600	0 ... 7,500
0 ... 750	0 ... 8,000
0 ... 800	

- 1) Measuring deviation $\leq \pm 0.7\%$ of span
 2) Non-linearity $\leq \pm 0.6\%$ of span BFSL

Vacuum and +/- measuring range

bar	
-1 ... +5 ¹⁾	-1 ... +24
-1 ... +9 ¹⁾	-1 ... +39
-1 ... +15	-1 ... +59

- 1) Non-linearity $\leq \pm 0.6\%$ of span BFSL

psi	
-30 inHg ... +100 ¹⁾	-30 inHg ... +300
-30 inHg ... +160	-30 inHg ... +500
-30 inHg ... +200	

- 1) Non-linearity $\leq \pm 0.6\%$ of span BFSL

The given measuring ranges are also available in kg/cm², kPa and MPa.
 Other measuring ranges on request.

Further details on: Measuring range	
Overpressure limit	The overpressure limit refers to the measuring range. Depending on the selected process connection and sealing, restrictions in overpressure limit can result. 2-fold
Vacuum resistance	Yes

3-fold overpressure limit on request

Process connection				
Standard	Thread size	Max. measuring range	Overpressure limit	Sealing
EN 837	G ½ B	400 bar [5,800 psi]	572 bar [8,290 psi]	-
	G ¼ B	600 bar [8,700 psi]	1,200 bar [17,400 psi]	
	G ¼ female thread	600 bar [8,700 psi]	1,200 bar [17,400 psi]	
	G ¾ B	600 bar [8,700 psi]	1,200 bar [17,400 psi]	
DIN EN ISO 1179-2 (formerly DIN 3852-E)	G ¼ A	600 bar [8,700 psi]	858 bar [12,440 psi]	<ul style="list-style-type: none"> ■ NBR ¹⁾ ■ FPM/FKM ²⁾
DIN EN ISO 9974-2 (formerly DIN 3852-E)	M14 x 1.5	600 bar [8,700 psi]	858 bar [12,440 psi]	
ANSI/ASME B1.20.1	½ NPT	400 bar [5,800 psi]	572 bar [8,290 psi]	-
	¼ NPT	600 bar [8,700 psi]	1,200 bar [17,400 psi]	
	¼ NPT female thread	600 bar [8,700 psi]	1,200 bar [17,400 psi]	
SAE J514 E	7/16-20 UNF-2A, O-ring BOSS	600 bar [8,700 psi]	858 bar [12,440 psi]	FPM/FKM ²⁾
	9/16-18 UNF-2A, O-ring BOSS	600 bar [8,700 psi]	858 bar [12,440 psi]	

1) Minimum permissible medium and ambient temperature range -30 °C [-22 °F]

2) Minimum permissible medium and ambient temperature range -15 °C [5 °F]

Details must be tested separately in the respective application. The values depend on the temperature, the seals used, the selected torque, the type and the material of the mating thread and the prevailing operating conditions.

Further details on: Process connection	
Max. measuring range	→ See above
Overpressure limit	→ See above
Sealing	→ See above
Pressure port diameter	3.5 mm
	For thread sizes G ¼ A, ¼ NPT and 7/16-20 UNF-2A, O-ring BOSS, following pressure port diameters on request: <ul style="list-style-type: none"> ■ 6 mm ■ 0.6 mm ■ 0.3 mm

Output signal	
Signal type	
Current (2-wire)	4 ... 20 mA
Voltage (3-wire)	■ DC 0.5 ... 4.5 V
	■ DC 0 ... 5 V
	■ DC 1 ... 5 V
	■ DC 0 ... 10 V
Ratiometric (3-wire)	DC 0.5 ... 4.5 V
Load in Ω	
Current (2-wire)	≤ (supply voltage - 8 V) / 0.02 A
Voltage (3-wire)	> maximum output signal / 1 mA
Ratiometric (3-wire)	> 4.5 kΩ

Output signal		
Voltage supply ¹⁾		
Supply voltage	Output signal 4 ... 20 mA	DC 8 ... 30 V
	Output signal DC 0.5 ... 4.5 V	DC 8 ... 30 V
	Output signal DC 0 ... 5 V	DC 8 ... 30 V
	Output signal DC 1 ... 5 V	DC 8 ... 30 V
	Output signal DC 0 ... 10 V	DC 14 ... 30 V
	Output signal DC 0.5 ... 4.5 V (ratiometric)	DC 5 V ± 10 %
Current supply	Current (2-wire)	Corresponds to the value of the output signal current (4 ... 20 mA), maximum 25 mA
	Voltage (3-wire)	5 mA
Overvoltage protection	DC 36 V	
Dynamic behaviour		
Settling time per IEC 61298-2	< 2 ms	

1) The power supply for the pressure sensor must be made via an energy-limited electric circuit in accordance with section 9.4 of UL/EN/IEC 61010-1 or an LPS to UL/EN/IEC 60950-1 or class 2 in accordance with UL1310/UL1585 (NEC or CEC). The power supply must be suitable for operation above 2,000 m should the pressure sensor be used at this altitude.

Other output signals on request.

Electrical connection					
Connection type	IP code ¹⁾	Wire cross-section	Cable diameter	Cable lengths	Cable material
Angular connector DIN 175301-803 A	IP65	-	-	-	-
Angular connector DIN 175301-803 C	IP65	-	-	-	-
Circular connector M12 x 1 (4-pin)	IP67	-	-	-	-
Delphi connector Metri-Pack series 150 (3-pin) ²⁾	IP67	-	-	-	-
Cable outlet					
Unshielded ³⁾	IP67	0.14 mm ²	3.4 mm	<ul style="list-style-type: none"> ■ 0.5 m ■ 1 m ■ 2 m ■ 5 m 	PVC
Shielded	IP67	0.14 mm ²	4.3 mm	<ul style="list-style-type: none"> ■ 0.5 m ■ 1 m ■ 2 m ■ 5 m 	PVC

1) The stated IP codes (per IEC 60529) only apply when plugged in using mating connectors that have the appropriate IP code.

2) Only possible from measuring range 0 ... 60 bar

3) To max. 80 °C [176 °F] permissible

Mating connectors are not included in the delivery, but they are available as accessories.

Other electrical connections on request.

Pin assignment

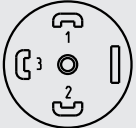
Angular connector DIN 175301-803 A			
		2-wire	3-wire
	U _B	1	1
	0V	2	2
	S+	-	3

Angular connector DIN 175301-803 C			
		2-wire	3-wire
	U _B	1	1
	0V	2	2
	S+	-	3

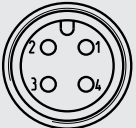
Circular connector M12 x 1			
		2-wire	3-wire
	U _B	1	1
	0V	3	3
	S+	-	4

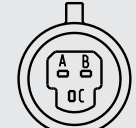
Delphi connector Metri-Pack series 150 (3-pin)			
		2-wire	3-wire
	U _B	B	B
	0V	A	A
	S+	-	C

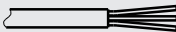
Cable outlet, unshielded			
		2-wire	3-wire
	U _B	Brown (BN)	Brown (BN)
	0V	Green (GN)	Green (GN)
	S+	-	White (WH)

Cable outlet, shielded			
		2-wire	3-wire
	U _B	Brown (BN)	Brown (BN)
	0V	Blue (BU)	Blue (BU)
	S+	-	Black (BK)

Version with connected shield on request

Legend

U _B	Positive power supply terminal
0V	Negative power supply terminal
S+	Positive output terminal

Further details on: Electrical connection	
Connection type	→ See above
Wire cross-section	→ See above
Cable diameter	→ See above
Cable length	→ See above
Pin assignment	→ See below
Ingress protection (IP code) per IEC 60529	→ See above
Short-circuit resistance	S+ vs. 0V
Reverse polarity protection	U _B vs. 0V
Insulation voltage	DC 750 V

Material	
Material (wetted)	Stainless steel 316L and 13-8 PH
	→ Sealing materials, see "Process connection"
	Oil- and grease-free versions on request
Material (in contact with the environment)	Stainless steel 316L and PBT GF 30
	→ Cable material, see "Electrical connection"



Operating conditions	
Medium temperature limit	-30 ... +100 °C [-22 ... +212 °F]
Ambient temperature limit	-30 ... +100 °C [-22 ... +212 °F]
Storage temperature limit	-30 ... +100 °C [-22 ... +212 °F]
Vibration resistance per IEC 60068-2-6	20 g (20 ... 2,000 Hz, 120 min)
Shock resistance per IEC 60068-2-27	40 g (6 ms), mechanical shock
Free fall per EN 60068-2-31	1 m
Service life	10 million load cycles

Other temperature ranges on request.





Packaging and instrument labelling	
Packaging	Multiple packaging (up to 50 pieces possible)
Instrument labelling	<ul style="list-style-type: none"> ■ WIKA product label, lasered ■ Customer-specific product label on request

Approvals

Approvals included in delivery

Logo	Description	Country
	EU declaration of conformity	European Union
	EMC directive EN 61326 emission (group 1, class B) and immunity (industrial application)	
	Pressure equipment directive	
	RoHS directive	
	EAC	Eurasian Economic Community
	EMC directive	

Optional approvals

Logo	Description	Country
	UL Safety (e.g. electr. safety, overpressure, ...)	USA and Canada
	GOST Metrology, measurement technology	Russia
	KazInMetr Metrology, measurement technology	Kazakhstan
-	MTSCHS Permission for commissioning	Kazakhstan
	BelGIM Metrology, measurement technology	Belarus
	UkrSEPRO Metrology, measurement technology	Ukraine
-	CRN Safety (e.g. electr. safety, overpressure, ...)	Canada

Manufacturer's information and certificates

Logo	Description
	MTTF:> 100 years
-	China RoHS directive

→ Approvals and certificates, see website

Dimensions in mm [in]

Pressure sensor

Angular connector DIN 175301-803 A

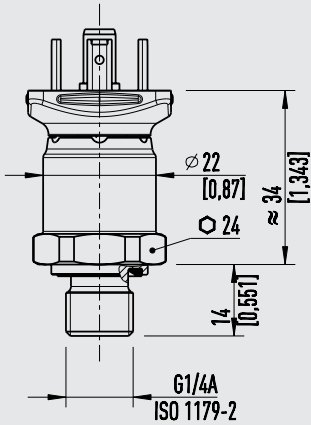

Weight: approx. 80 g [0.176 lbs]

Angular connector DIN 175301-803 C

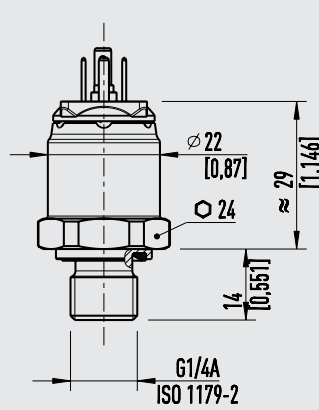

Weight: approx. 80 g [0.176 lbs]

Circular connector M12 x 1

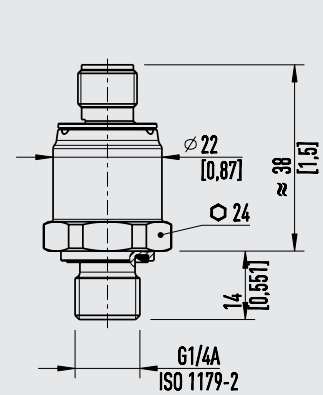

Weight: approx. 80 g [0.176 lbs]

Delphi connector Metri-Pack series 150

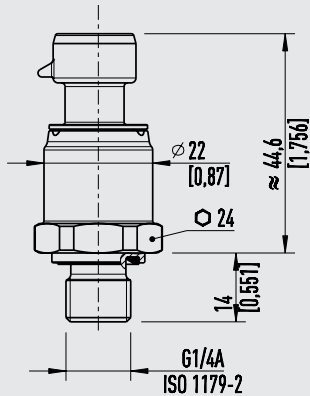

Weight: approx. 80 g [0.176 lbs]

with cable outlet

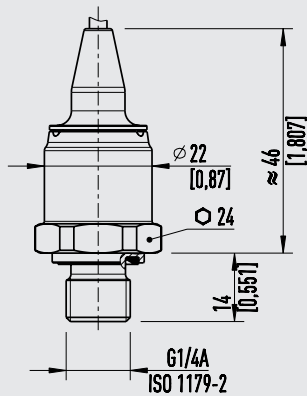

Weight: approx. 80 g [0.176 lbs]

Process connections

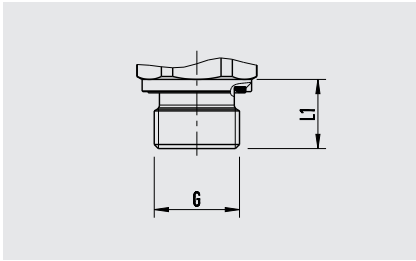

G	L1
G ¼ A DIN EN ISO 1179-2	14 [0.55]
M14 x 1.5 DIN EN ISO 9974-2	14 [0.55]

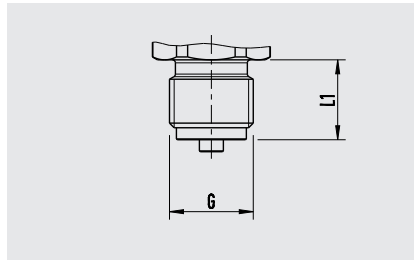

G	L1
G ¼ B EN 837	13 [0.51]
G ⅜ B EN 837	16 [0.63]

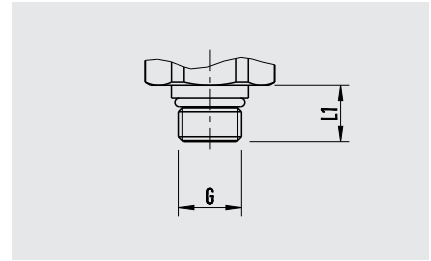

G	L1
9/16-18 UNF BOSS SAE J514 E	12.85 [0.506]
7/16-20 UNF BOSS SAE J514 E	12.06 [0.475]

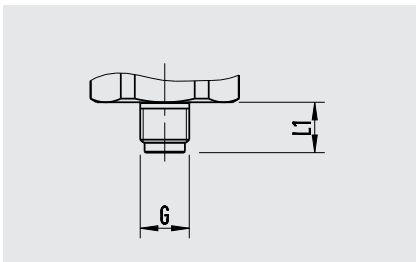

G	L1
G ⅝ B EN 837	10 [0.39]

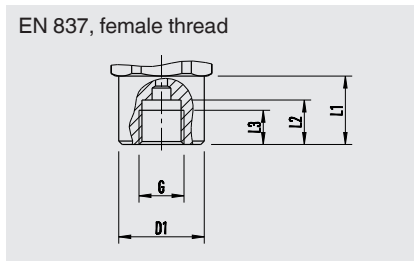

G	L1	L2	L3	D1
G ¼	17 [0.67]	13 [0.51]	10 [0.39]	Ø 19 [0.75]

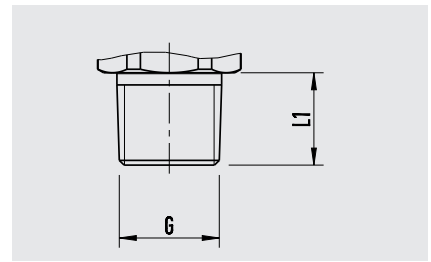

G	L1
⅝ NPT ANSI/ASME B1.20.1	10 [0.39]
¾ NPT ANSI/ASME B1.20.1	13 [0.51]

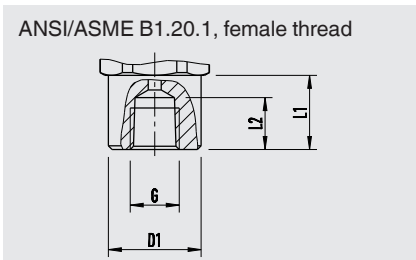

G	L1	L2	D1
¼ NPT	17 [0.67]	14 [0.55]	Ø 19 [0.75]

→ For information on tapped holes and welding sockets, see Technical information IN 00.14 at www.wika.com.

Accessories

Description	Version	Order number
Mating connector		
Angular connector DIN 175301-803 A	Gland PG9	11427567
	With 2 m cable	11225793
	With 5 m cable	11250186
	Conduit ½ NPT	11022485
Angular connector DIN 175301-803 C	Gland PG7	1439081
	With 2 m cable	11225823
	With 5 m cable	11250194
Circular connector M12 x 1, 4-pin, straight	Without cable	2421262
	With 2 m cable	11250780
	With 5 m cable	11250259
Circular connector M12 x 1, 4-pin, angled	Without cable	2421270
	With 2 m cable	11250798
	With 5 m cable	11250232
Sealings for mating connectors, blue (WIKA)		
Angular connector DIN 175301-803 A		1576240
Angular connector DIN 175301-803 C		11169479

Only use the accessories listed above, otherwise it could lead to the loss of the approval.

Ordering information

Model / Measuring range / Design / Process connection / Sealing / Pressure port / Output signal / Electrical connection / Approval

© 09/2011 WIKA Alexander Wiegand SE & Co. KG, all rights reserved.
 The specifications given in this document represent the state of engineering at the time of publishing.
 We reserve the right to make modifications to the specifications and materials.

